

3.7. WORKFLOW DIAGRAM (STABILIZATION MEDIUM - LOAD 136 kg - 230 kg - 330 kg - 500 kg)

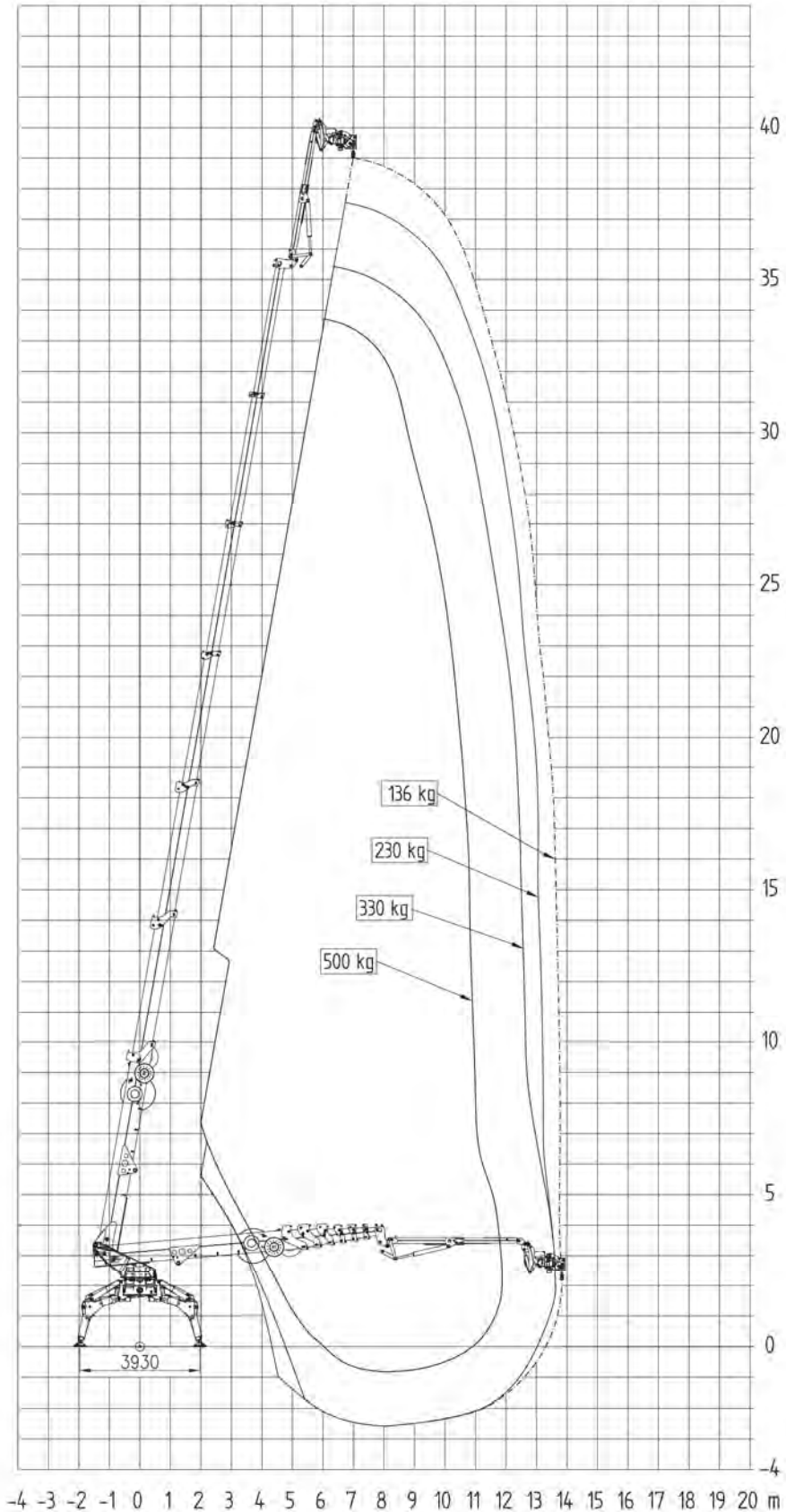

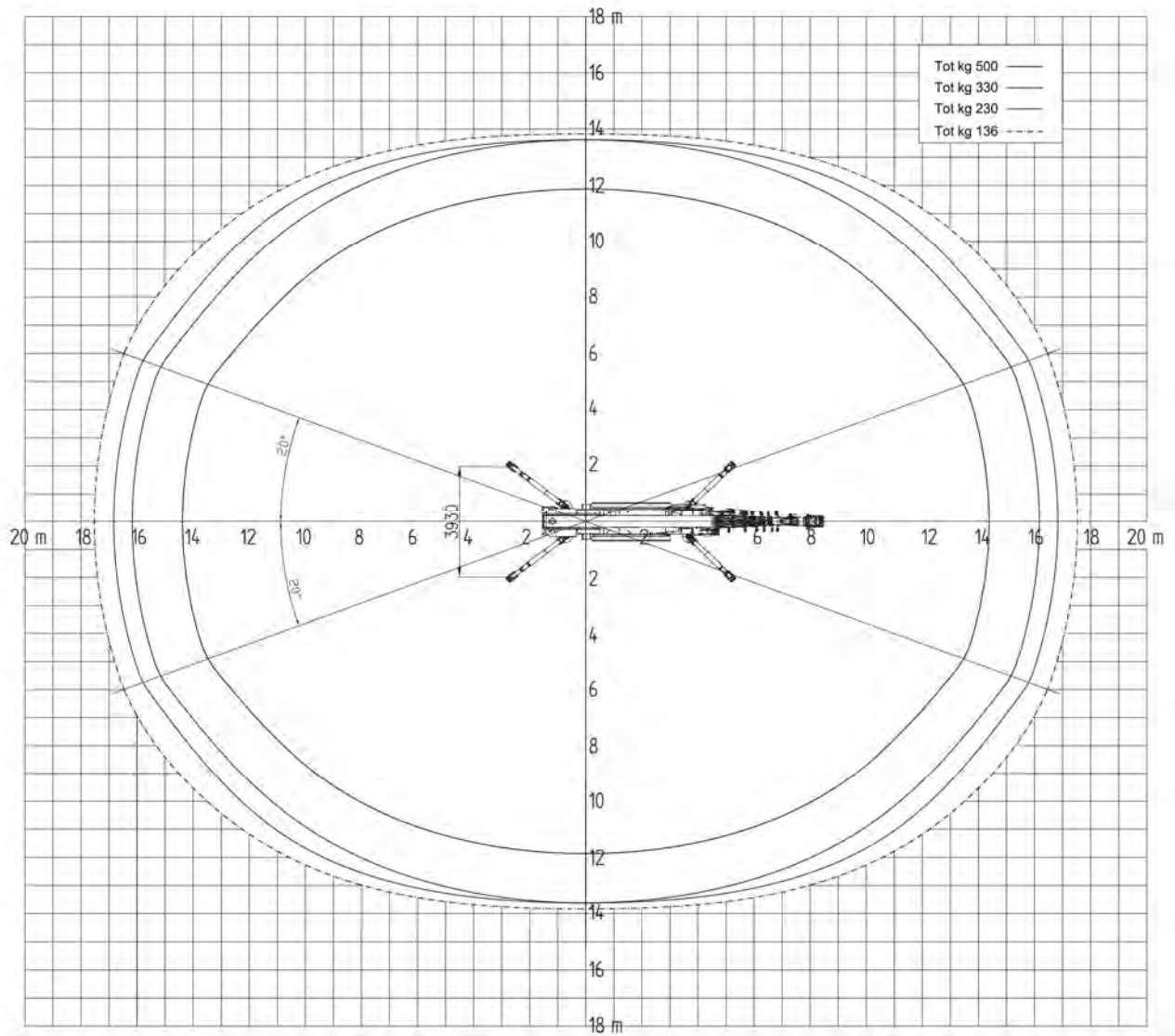

3.8. WORKFLOW DIAGRAM (WIDE STABILIZATION - 136 kg - 230 kg - 330 kg - 500 kg LOAD)

