

3.6.3. NARROW STABILISATION 2200/800
(136 - 250 - 300 kg) (300 - 551 - 661 lb)

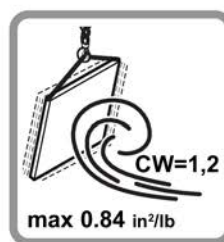

3.6.4. WIDE STABILISATION 2200/800
(136 - 250 - 300 kg) (300 - 551 - 661 lb)

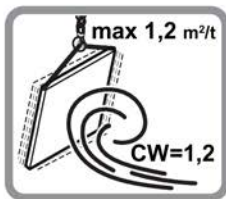
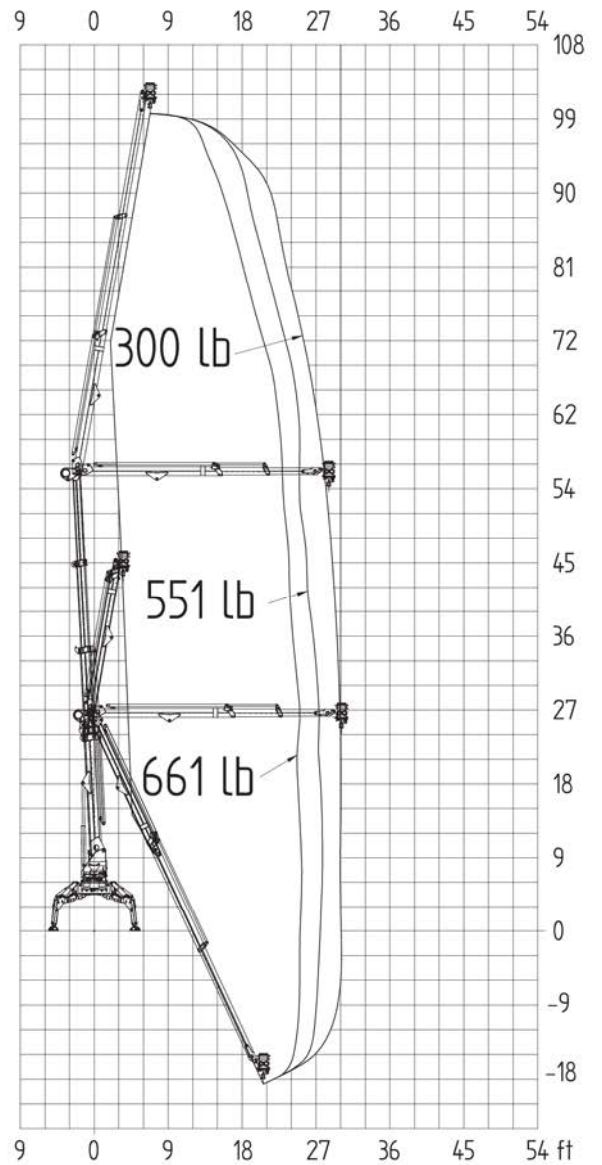
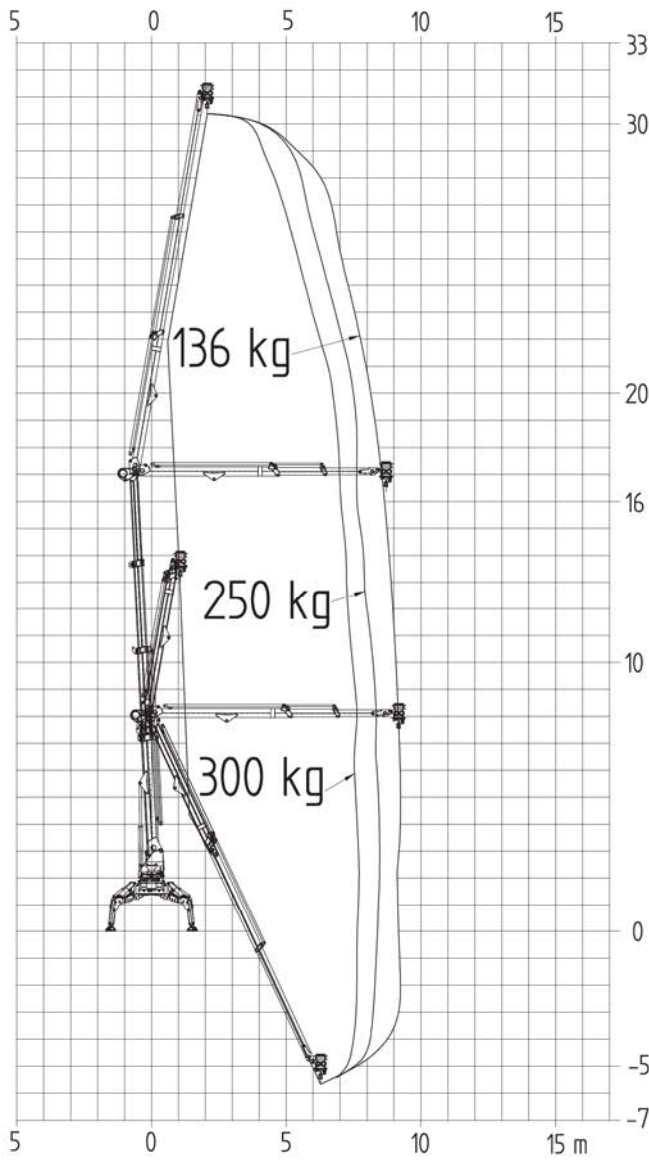