

# PERTH PICKER HIRE

THE TRACK MOUNTED SPECIALIST

## PB43T/400 43M

Cherry Picker Specification Guide



**ABOUT PB43T/400**

With a massive 43 m of working height, and over 18 m of horizontal outreach, the new Monitor 43T Spider Lift is truly a formidable weapon. With a basket capacity of 400 kg, this machine has the ability to tackle the biggest jobs where size really does matter!

Enormous stabilizer leg travel allows the Monitor 43T to set up and operate in the most challenging terrain. The Monitor 43T's powerful track drive will ensure it gets to the location with ease.

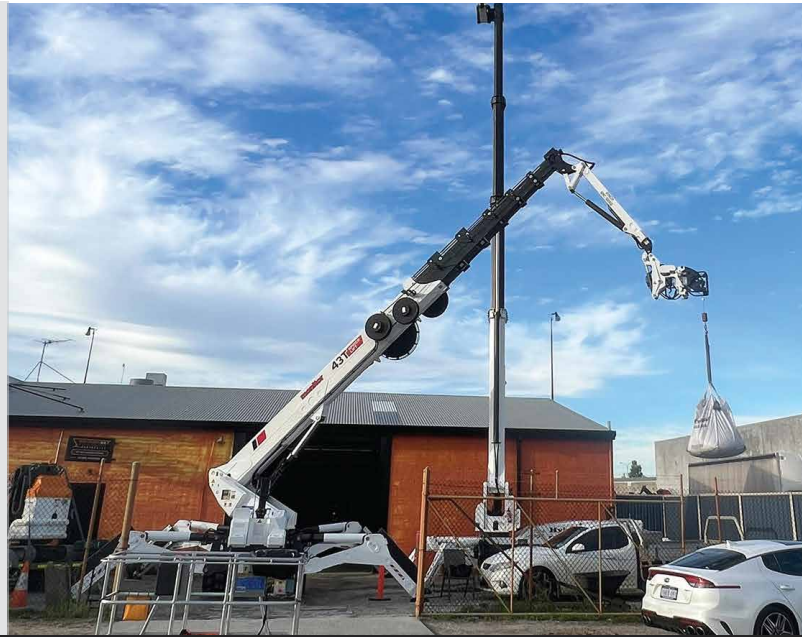

**PB43T/400 SPECIFICATIONS**

**Max Working Height**  
43.18m

**Max Working Height in Narrow Set**  
40.50m

**Max Horiz Outreach**  
18.69m

**Max Rated Capacity**  
400kg

**Weight: Engine + Lithium Batteries**  
LBD 12920kg

**Turret Rotation**  
Continuous 360°

**Basket Rotation**  
180°

**Ground Pressure Driving**  
92.35kN/m<sup>2</sup>

**Max Stabiliser Force**  
94kN

**Max Stabiliser Pressure (std Foot Pad)**  
93.6kN/m<sup>2</sup>

**Tracks Retracted**  
1.99m High

**Traffic Load (Live Load) Travelling**  
6.0kN/m<sup>2</sup>

**Traffic Load (Live Load) Stabilised Wide**  
4.2kN/m<sup>2</sup>

**Traffic Load (Live Load) Stabilised Narrow**  
4.9kN/m<sup>2</sup>

**Auto Levelling**  
Std

**Max Slope for Stabilisers (No Extra Pads)**  
25°

**Gradeability Lengthwise**  
15°

**Gradeability Sideways**  
17°

**Standard Engine**  
Kubota 37Hp Diesel

**Dual Power Options**  
Lithium Batteries

**Expanding Tracks**  
Std

**Max Drive Speed**  
1.5km/h

**Radio Control**  
Std

**Electric Emergency Lowering**  
Std

**Hydraulic Winch**  
Optional

**PB43T/400 TECHNICAL DRAWINGS**

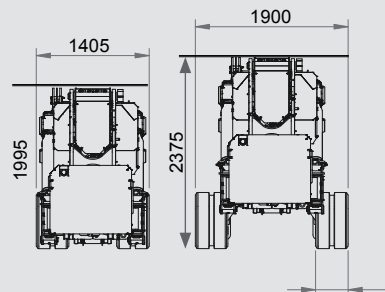
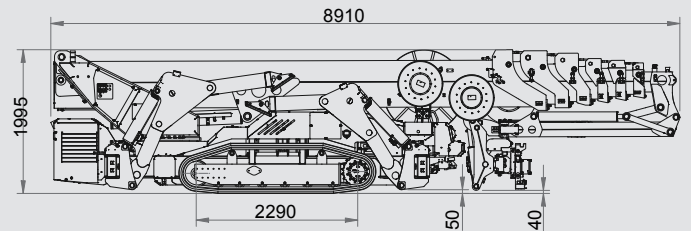
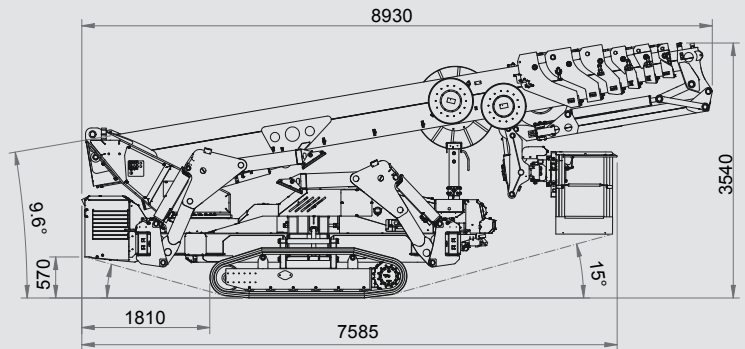
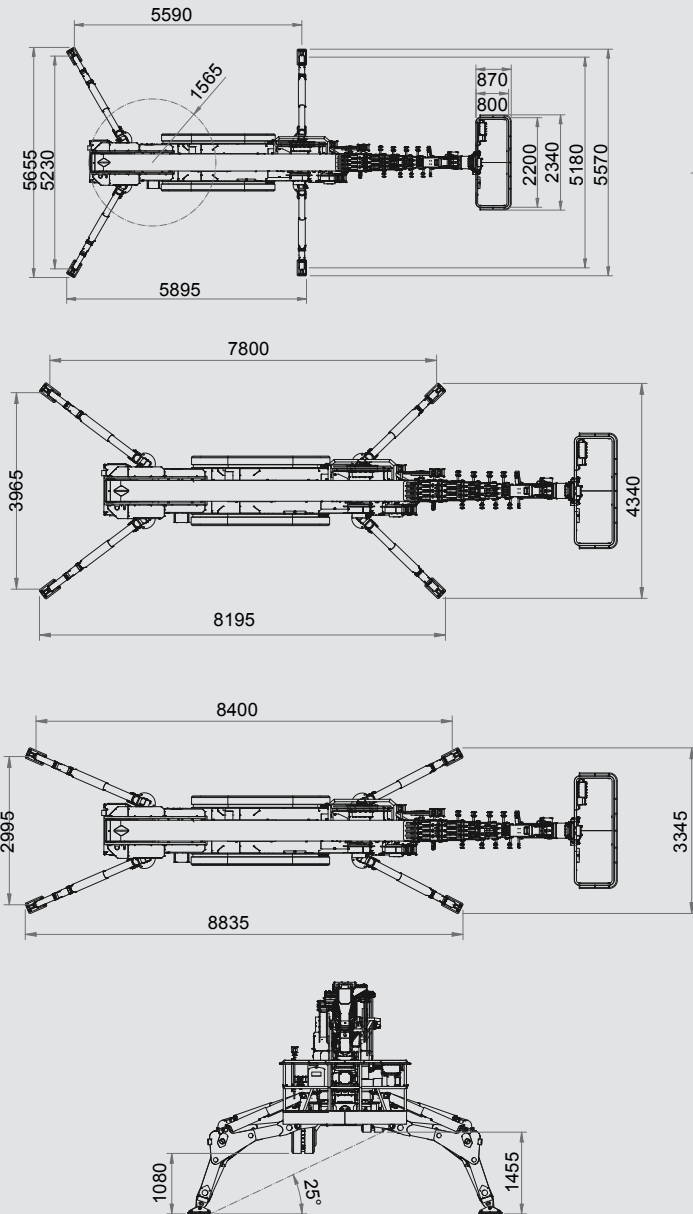

**500kg Winch**

Switch out your Spider Lift's basket to a 500kg Lifting Winch when needed.

Transform your Spider Lift to a Spider Crane, and easily hoist materials easily.

**PERTH PICKER HIRE**  
THE TRACK MOUNTED SPECIALIST